

IMPROVING THE PERFORMANCE OF SOLAR POWER PLANTS IN GRID CONNECTED MODES USING ALTRUISTIC TRANSFORMATIVE ALGORITHM

R. Palanisamy¹, K. Sathiyasekar², P.L.N. Ramesh³ and K.G. Parthiban⁴

¹Department of Electrical Electronics Engineering, Builders Engineering College, India

²Department of Electrical Electronics Engineering, Prathyusha Engineering College, India

³Department of Mechanical Engineering, Prathyusha Engineering College, India

⁴Department of Electrical Sciences, Adithya Institute of Technology, India

Abstract

Distributed Generation systems (DGs) using solar is one of the new trends of power generation. These distributed generating units are integrated to form a micro grid and to serve the loads among the locality, which is in connection with the utility grid for power exchange. These distributed generation systems can be operated at two modes, Grid connected mode, and standalone mode. Distributed Generation (DGs) can provide high reliability by providing on-site generation and its advantages like the elimination of transmission losses, utilization of green fuels and reduction of load demand upon the utility grid resulting in a reduction of fossil fuel consumption. Many DGs are available like Photovoltaic (PV) cells, wind turbine, diesel and small hydro systems. However the output of solar arrays varies due to change of solar irradiation and weather conditions. In this work Altruistic Transformative method based HOMER design tool is used for the simulation and analysis of the solar power system which simplifies the task of evaluating designs. HOMER's optimization and sensitivity analysis algorithms make it easier to assess a possible number of design configurations. It provides highly possible simulation results compared to the other conventional techniques. Over 95% efficiency is achieved by using an Altruistic Transformative method based HOMER solar grid design, when compared with other techniques like Fuzzy and Incremental Conductance (INC).

Keywords:

Photovoltaic System, Distributed Generators, HOMER Software, Boost Converter, Grid Tie Inverter, Fuzzy Logic Controller

1. INTRODUCTION

Renewable energy sources such as solar, biomass, hydroelectric, geothermal, and wind electricity generation have emerged as potential options which address some of these concerns [1] [2]. This system forms a Micro grid which ranges in size from a small residential application to small city-size islands with 100 MW load. Solar power generation has many advantages over other forms of power generation, i.e. reduced dependence on fossil fuels, environmental benefits, matching peak time output with peak time demand, modularity, scalability, flexible locations, and government incentives [3]. Micro grid is an energy system that uses different types of renewable energy resources, energy generators, energy storage systems, and loads and power conditioning units.

Implementation of renewable energies such as solar energy will lead to economic, social and environmental benefits. The significant research was done in the field of grid connected PV system. One of the essential requirements, for a hybrid energy system, is to ensure continuous power flow by collecting excess energy from the renewable sources

Although battery technology has reached a very suppurate stage; size, cost, and disposal are the constraining factors for its use in stand-alone remote applications [4] [5]. However, due to the high cost of energy storage, an autonomous system is costly [6]. Therefore, it is essential to find an effective solution to this problem. On the other hand, grid connected hybrid power system with proper planning requires storage with less capacity which, in turn, reduces the cost.

The main objective of this work is to design a solar energy system to meet the desired electric load with a high renewable fraction little excess power, low leveled cost of energy and with low environmental impacts (reduce the carbon foot print emissions). Simulation, modeling, and optimization using HOMER software and Simulink [7]-[10] is used to identify the optimal off-grid options.

The rest of this paper organized into seven section: section 1 deals with the introduction part of the paper. Section 2 deals with the research background and section 3 deals material and methods of the solar power grid. Section 4 deals with the Altruistic Transformative Algorithm (ATA). Section 5 deals with results and discussion. Finally, section 6 describes the conclusion part.

2. RESEARCH BACKGROUND

At present, PV power has widely used in stand-alone power systems in remote villages, particularly in a hybrid with diesel power generators. Its primary components are PV module, charge controller, battery, and inverter. Batteries store the energy and provide a constant source of energy. The charge controller is used to control the flow of current into and out of the battery. It prevents the battery from overcharging and completely discharging [11].

In the grid-connected PV system, electronic power inverters are needed to realize the power conversion, grid interconnection, and control optimization [12]. Grid-connected Pulse Width Modulation (PWM) and Voltage Source Inverters (VSI) is widely applied in PV systems [12] [13]. For the inverter based PV system, the conversion power quality including the low THD, high power factor and fast dynamic response, mostly depends on the control strategy adopted by the grid-connected inverters. Various methods have been purposed to synchronize the grid and PV to supply of the load [14] [15]; however, this is not feasible for places where grid cut-off is a common problem. It is apparent that utilization of renewable energy resources might be useful to reduce environmental problems and increase the power generation. The commitment of micro grids will cause power quality improvement. Micro grids can provide ancillary services such as voltage regulation by reactive power supplement and

mobile power storage. The researchers investigated the advantages and disadvantages of renewable resources, restrictions in an application of hybrid systems, optimization of micro grids, environmental pollution and emission reduction, improvement in final cost of a system and finally deliberate operation of micro grids and intelligent networks.

In this study, the micro grid provides its energy from photovoltaic panels and major network. The both storage unit of battery store the excess generated power of generating units, and deliver them in a case of power deficiency. In this work, the HOMER software is used as an optimization tool to determine the size and energy management of the system. Moreover, the consideration of many changes and uncertainties in input data is possible to achieve the most economical state.

It is discovered that the framework has an issue with solar power generation in all the above methodologies. With the goal that another propelled technique has proposed in this work. This work discloses how to enhance the productivity of the dual converter power supply system using Altruistic Transformative Algorithm (ATA) technique. The simulation work does with the Matlab condition, the simulation result comes about demonstrate the adequacy of the proposed method and its capacity to control solar power generation.

3. PROPOSED METHOD

A proposed solar power system consists of PV module, DC – DC converter, bidirectional converter, battery bank and inverter. The schematic diagram of a primary proposed solar power grid system has shown in Fig.1.

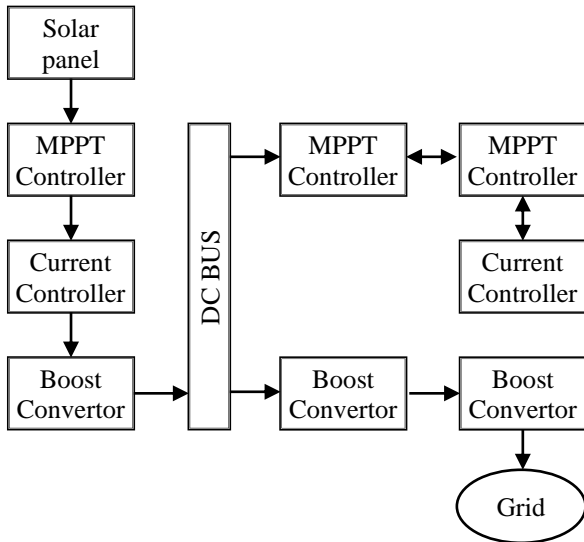

Fig.1. Proposed PV power grid

The MPPT control and converters operations are employed to control the solar power system by using ATA. The boost converter performs Maximum Power Point Tracking (MPPT) of a PV system. A battery bank has a DC-DC bi-directional converter and it is used for charging and discharging application of battery bank. The solar panel powers the load and charges the battery through a buck converter which acts as a maximum power point tracker using ATA.

A boost converter converts the low DC voltage output from the battery bank to the regulated bus voltage. DC grid is connected to the solar system for power exchange. An inverter acts as an Interlink between the dc-connect part and the Point of Common Coupling (PCC).

During the night time, when solar power is not available, and the battery can regulate the frequency and voltage of the stand-alone PV power system. That facilitates charging the battery from the distribution system to maintain constant dc-link voltage when power is not available from the PV.

4. DC TO DC BOOST CONVERTER

The converter is connected between the DC-bus and the AC-bus as shown in Fig.2. The converter is modeled based on its rated capacity and efficiency, which are assumed to be constant throughout its operating range. The circuit diagram of the boost converter is given as in Fig.2.

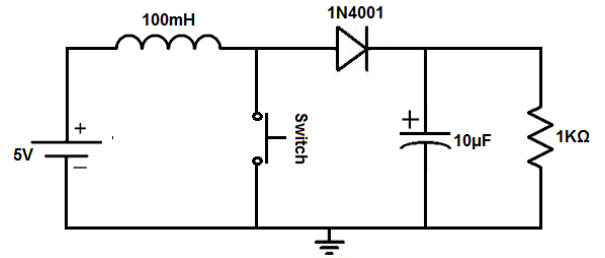

Fig.2. DC-DC Boost Converter

The general design equations of the boost converter are given in Eq.(1):

$$V_L = \frac{V_s}{1 + \sigma} \tag{1}$$

where, V_L is the output voltage, V_s is the source voltage, and σ is the duty cycle. The minimum inductance required for operation in Continuous Conduction Mode (CCM) is L_{min} , and it is designed to be higher, σ is the duty cycle, R_L is the load resistance, and F_s is the switching frequency of the MOSFET.

$$L_{min} = \left((1 - \sigma)^2 \sigma_{RL} \right) 2f_s \tag{2}$$

The capacitor value is designed such that the voltage ripple must be minimum, the value of capacitance is given for the voltage ripple V_r as in Eq.(3).

$$C_{min} = \frac{\sigma}{Rf_s V_r} \tag{3}$$

The output voltage depends upon the value of the duty cycle which is responsible for the constant output voltage. The load current I_o is also dependent on the duty cycle, and it is given in Eq.(4).

$$I_o = (1 - \sigma) I_s \tag{4}$$

where I_s is the source current. The change in the current due to the value of inductance is given as in Eq.(5).

$$\nabla I = V_s \frac{(V_l - V_s)}{f_s L V_l} \tag{5}$$

5. GRID TIE INVERTER

The DC voltage is converted into AC voltage, and it is fed to the grid using a grid tie inverter. The grid tie inverter used here is voltage source converter with PWM technique. Design equation of grid tie inverter is followed.

$$X_b = (E_n)^2 P_n \tag{6}$$

$$B_b = 1/(W_n Z_b) \tag{7}$$

$$W_n = W_b \tag{8}$$

where, W_n is the grid frequency, E_n is a line to line RMS voltage, and P_n is an active power. The DC capacitor can be designed using Eq.(9).

$$C \geq \frac{T_r \Delta P I_{max}}{2V_o \Delta V_o} \tag{9}$$

where, T_r is current control, ΔV_o is the DC voltage variation and ΔP_{max} is the maximum power variation of the DC bus. The design equation for the AC side capacitor is given as in Eq.(10):

$$C_f = 1 - \frac{IG}{2b^2} \tag{10}$$

The converter side inductance is given by Eq.(11).

$$l = \max \left(\frac{V(n)}{nW_b I_{Limit}(n)} \right) \tag{11}$$

where, $v(n)$ is the voltage generated at n -harmonic by the VSC and $I_{Limit}(n)$ is the maximum tolerable current ripple at the n -frequency.

5.1 ATA FOR GRID AND PHOTOVOLTAIC PANEL OPTIMIZATION

To have a safe and cost efficient power generating system, an optimization algorithm based on altruistic transformative algorithm has proposed. The Fig.3 shows the diagram of the proposed algorithm in which the ATA block represents the altruistic transformative algorithm.

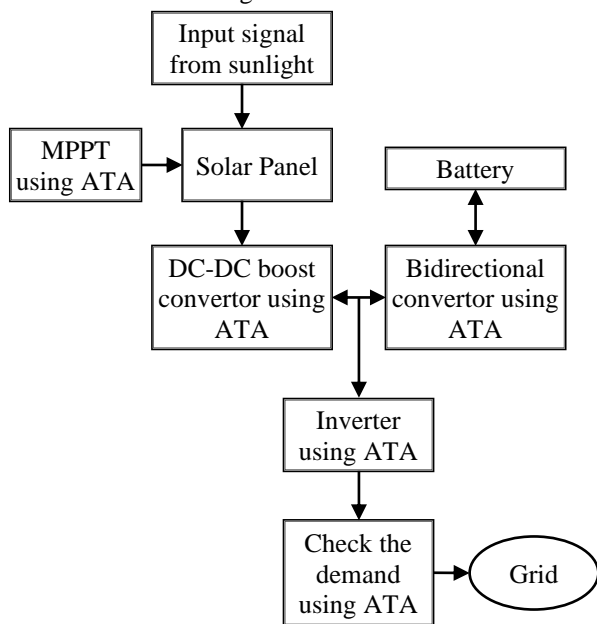

Fig.3. Altruistic Transformative Optimization Algorithm

The generated photovoltaic power is compared with demand power if it is larger than the request than with the comparatively good fitness ($f > 1$) it goes to the processes of ATA. If the generated power does not match with input demand (lower power than load),

The comparison code produces a relatively low fitness ($f < 1$) then continues with ATA optimization process. Since the ATA generates and keeps populations with the best fitness, it generates as much power as the demand. The cost values have considered by the algorithm such that the lowest cost solution which meets the demand has produced.

The optimization methodology to determine the configuration and sizing for hybrid energy sources, simultaneously considering economic, technical and environmental objectives as well as satisfying three constraint conditions, was developed using the ATA. This technique is considered as one of the most powerful evolutionary algorithms for real number function optimization nowadays.

The ATA algorithm has explained in the following steps.

- Step 1: Initialization:** puts the iteration $t=0$ and generates the randomly m population. $[X_i(0), i=1, \dots, m]$, $X_i(0) = [X_{j1}(0), X_{j2}(0), \dots, X_{jn}(0)]$, will generate in searching space $[X_r^{2min}, X_r^{max}]$ randomly.
- Step 2: Mutation:** Generate a random integer for F
- Step 3: Fitness:** evaluating each population in the initial population using the objective function.
- Step 4: Time update:** updates the time counter $t=t+1$.
- Step 5:** Generate another population by repeating by the following steps until the population is done:
- Step 6:** Create a random integers is CR (crossover) (Mutation) Randomly select three populations from Eq.(12).

$$X_j(t) \text{ s.t. } X_j, r_1(t), r_2(t), r_3(t) \tag{12}$$

A sample vector $y_i(t)$ is denote as in Eq.(13).

$$y_i(t) = X_j, r_1(t) + F(X_j, r_2(t) - X_j, r_3(t)) \tag{13}$$

Cross over candidate vector $X_j(t)$ is obtained through cross over operator involving the vectors is defined as in Eq.(14).

$$X_j(t) = \begin{cases} y_j(t) & \text{if } rand(0,1) \leq CR \\ X_{j,i}(t) & \text{if } rand(0,1) > CR \end{cases} \tag{14}$$

The collection methods involve a straight forward replacement of the original parameter vector with the applicant vector if the concern function decreases by such an action. If current population is less than old community, the operation has continued or else go to step 6. Step 6 is the process stop if one of the stopping criteria was detected, else go back to step 2.

6. RESULTS AND DISCUSSION

The Fig.4 shows HOMER based solar power system simulation diagram

Table.1. Simulation Parameters

Parameter	Values
Software tool	HOMER tool and data synthesizer
Range	1010×1010m

Plenty of users	1500
Running time	103-451 s
Plenty of source for energy providers	1
Renewable power generation source	Solar PV array

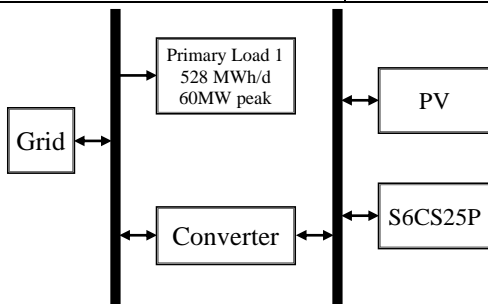

Fig.4. HOMER Solar Grid

The Table.1 shows the simulation parameters used to assess the proposed altruistic transformational optimization algorithm. The specifications and the relative preservation and launching costs of solar PV arrays, and batteries, which are input to the optimal sizing procedure, are listed in following Table.2 and Table.3.

Table.2. Solar PV Array Data

Parameter	Values
Output Voltage $V_{oc}(v)$	2700V
Source Current I_{sc} (A)	35A
Lifetime of the PV panel (year)	6 years
Installation cost (Rs)	6.5 Lakhs
Operation and maintenance (Rs)	0.75 Lakhs

Table.3. Battery Specification

Parameter	Values
Voltage	90%
Nominal Capacity	200 Ah
Date of discharge	90%
Lifetime of the battery (year)	10 years
Installation cost (Rs)	12 Lakhs
Operation and maintenance (Rs)	3.6 Lakhs

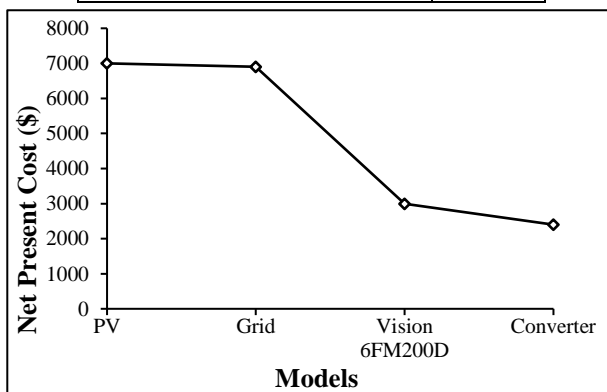

Fig.5. HOMER Cash Flow Summary

The Fig.5 shows the minimization of the system total cot has achieved by selecting an appropriate system Configuration. Battery bank state of charge, PV output, boost converter and inverter output. All these figs show the real condition of a battery bank, inverter and PV module output throughout the year by an hourly load. It is clear that the battery is discharged slowly after the sunset and during the day time its discharge is pretty small

Besides these plots, HOMER gives the following data for this stand-alone system which are provided in Table.4.

Table.4. Output Result of HOMER

Parameter	Values
PV output	9.12 KWh/day
Capacity Factor of PV	16.8%
Total production of PV	3342 KWh/year
Nominal capacity of battery	200 Ah
Useable capacity of battery	180 Ah
Battery Autonomy	33.6 Hr
Inverter output	0.234 Kw
Capacity factor of inverter	7.8%

In Table.4, it indicates the resulted optimum sizes of the different components included in the hybrid system using HOMER simulation.

Table.5. Cost Comparison of Different Methods

Feature	Cost (lakhs)
INC	91.8
Fuzzy	73.2
ATA	50.3

The Table.5 shows a comparison between the expenses that resulted from solving the formulated optimization problem by using the proposed ATA-based technique and some other algorithms using HOMER software.

The Table.6 indicates that the proposed ATA-based technique is better than to another algorithm.

Table.6. Comparison of Proposed Model

Controller	Output power in per unit	Switching Loss (%)	Maximum output power efficiency (%)
Cost	0.87	18	83.72
Physical Structure	0.91	12	88.55
Resistance to work environment	0.97	7	95.92

The Table.5, shows Maximum power tracking Efficiency comparison of different converters with proposed converter system has provided an efficient result to other conventional techniques. From the investigation of reproduction results in the different parameters, for example, switching losses, maximum output power and efficiency estimations of converters (Fig.5) are recorded in Table.6.

Conventional Incremental Conductance (INC), Fuzzy (FLC) and Proposed ATA Controller have the Efficiency values of 84.72%, 89.55%, and 99.92% respectively. The comparison shows the effectiveness of the proposed under a different level of control index (Table.7). It is seen that the proposed method provides the practical result and more service availability than other algorithms.

From the above analysis performed, the proposed altruistic transformative optimization method has been assessed with various parameters and has created significant results with all factors of optical properties and grouping.

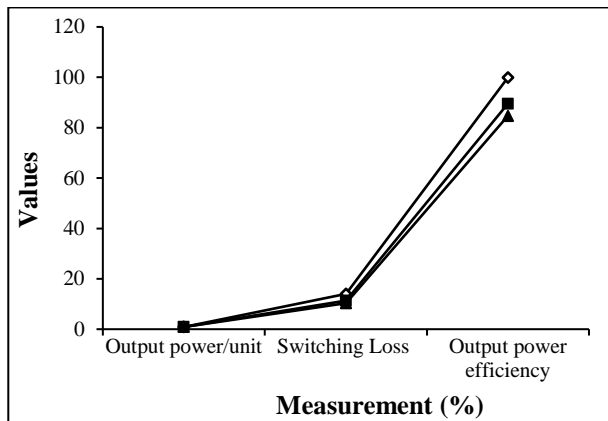

Fig.5. Comparison of various controllers

Table.7. Comparison of Features from Different Algorithm

Feature	INC	Fuzzy	ATA
Cost	High	High	Low
Physical Structure	Big	Big	Small
Resistance to work environment	High	High	Low
Fault finding	Difficult	Difficult	Very easy
Communication	Difficult	Easy	Very easy
Production Planning	Moderate	Difficult	Easy
Security	Low	Moderate	High
Monitoring Data	Unavailable	Moderate	Very easy

The Table.4, discuss the comparison features of a different algorithm as compared to other conventional technique the proposed method gives a perfect result. From the above all analysis performed, the proposed design has been evaluated with various parameters and produced accuracy results as compared to other conventional methods

7. CONCLUSION

The design of a stand-alone system has been accomplished successfully by using PV system and HOMER. In the case of PV system, it shows mismatch with possible data to a small extent. The output result generated by Battery bank has a significant similarity with reliable data. For a detailed design and economic analysis of a stand-alone or grid tie, a solar system is a good choice. HOMER would be preferable for hybrid solar system design, optimization and sensitivity analysis.

The simulation results show that grid connected power system which includes solar is less cost effective than without grid connected system. Thus HOMER is advantageous in performing stable energy configuration for each hour to choose the possible shape. This cost estimation of any possible combination for installing and operating over the life time in a particular area can successfully be analyzed using the proposed methodology. As compared to other HOMER grid design the advanced altruistic transformative Based HOMER solar grid design achieved more the 95% efficiency.

REFERENCES

- [1] P.B. Ngancha, K. Kusakana and E. Markus, "A Survey of Differential Flatness-Based Control Applied To Renewable Energy Sources", *Proceedings of International conference on Power Africa*, pp. 424-428, 2017.
- [2] Vishal Dabra, Krishan Kumar Paliwal, Pradeep Sharma and Narender Kumar, "Optimization of Photovoltaic Power System: A Comparative Study", *Protection and Control of Modern Power Systems*, Vol. 2, pp. 1-11, 2017.
- [3] Chiemeka Onyeka Okoye and Oguz Solyali, "Optimal Sizing of Stand-Alone Photovoltaic Systems in Residential Buildings", *Energy*, Vol. 126, pp. 573-584, 2017.
- [4] R. Nagaraj, "Renewable Energy based Small Hybrid Power System for Desalination Applications in Remote Locations", *Proceedings of IEEE International Conference on Power Electronics*, pp. 1-5, 2012.
- [5] Gazinga Abdullah, David Whaley and Wasim Saman, "Comparison of Mains versus Standalone PV Electricity to Power Residential Standalone Solar Absorption Chiller in Australia", *Energy*, Vol. 110, pp. 504-509, 2017.
- [6] O.R. Chowdhury, H. Kim, Y. Cho and J. Park, "Optimization of a Hybrid Renewable Energy System with HOMER", *Advances in Computer Science and Ubiquitous Computing*, Vol. 373, pp. 93-99, 2015.
- [7] O.H. Mohammed, Y. Amirat and M.E.H. Benbouzid, "Optimal Design and Energy Management of a Hybrid Power Generation System Based on Wind/Tidal/PV Sources: Case Study for the Ouessant French Island", *Green Energy and Technology Book Series Springer*, pp. 381-413, 2017.
- [8] Ojin Kwon and Yong-Jin Yoon, "Optimizing Present Power Distribution System and Novel Renewable Energy Sources for Tamil Nadu in India using HOMER", *International Journal of Revision Engineering and Manufacturing*, Vol. 15, No. 8, pp. 1695-1701, 2014.
- [9] N.A. Awadhi and M.S.E. Moursi, "A Novel Centralized PV Power Plant Controller for Reducing the Voltage Unbalance Factor at Transmission Level Interconnection", *IEEE Transactions on Energy Conversion*, Vol. 32, No. 1, pp. 1-14, 2017.
- [10] Hany M. Hasanien, "Whale Optimisation Algorithm for Automatic Generation Control of Interconnected Modern Power Systems Including Renewable Energy Sources", *IET Generation, Transmission and Distribution*, Vol. 12, No. 3, pp. 607-614, 2018.
- [11] Arobinda Dash, Durgesh Prasad Bagarty, Prakash Kumar Hota and Sribatsa Behera, "A Review on Control Strategies of Grid Connected Solar PV Generating System",

- International Journal of Engineering and Technical Research*, Vol. 2, No. 9, pp. 27-35, 2014.
- [12] Akshay S. Shirbhate and D. Jawale, "Power Quality Improvement in PV Grid Connected System by using Active Filter", *Proceedings of International Conference on Energy Efficient Technologies for Sustainability*, pp. 388-395, 2016.
- [13] A. Shanmughapriya, P. Saranya and S. Angeline Sreeja, "Synchronization of Power from Grid and PV System with MPPT based on Incremental Conductance Technique", *International Journal of Research in Engineering and Technology*, Vol. 3, No. 7, pp. 41-48, 2014.
- [14] R. Dhanapal and P. Visalakshi, "Efficient Clustering Protocol based on Ant-Bee Agent for Large Scale MANET", *International Journal of Applied Engineering Research*, Vol. 10, No. 52, pp. 349-361, 2015.
- [15] Muhammad Waqas Khan, Muhammad Saleem, Ashfaq Ahmad and Ahmad Ayaz, "Synchronization of Photo-Voltaic System with a Grid", *IOSR Journal of Electrical and Electronics Engineering*, Vol. 7, No. 4, pp. 1-5, 2013.