

REAL TIME WIRELESS AIR POLLUTION MONITORING SYSTEM

Raja Vara Prasad Y¹, Mirza Sami Baig², Rahul K. Mishra³, P. Rajalakshmi⁴, U. B. Desai⁵ and S.N. Merchant⁶

^{1,2,4,5}Department of Electrical Engineering, Indian Institute of Technology Hyderabad, India

E-mail: ¹ee10p004@iith.ac.in, ²sami@iith.ac.in, ⁴raji@iith.ac.in, ⁵ubdesai@iith.ac.in

^{3,6}Department of Electrical Engineering, Indian Institute of Technology Bombay, India

E-mail: ³rahulkmishra@ee.iitb.ac.in, ⁶merchant@ee.iitb.ac.in

Abstract

Air pollution has significant influence on the concentration of constituents in the atmosphere leading to effects like global warming and acid rains. To avoid such adverse imbalances in the nature, an air pollution monitoring system is utmost important. This paper attempts to develop an effective solution for pollution monitoring using wireless sensor networks (WSN) on a real time basis namely real time wireless air pollution monitoring system. Commercially available discrete gas sensors for sensing concentration of gases like CO₂, NO₂, CO and O₂ are calibrated using appropriate calibration technologies. These pre-calibrated gas sensors are then integrated with the wireless sensor nodes for field deployment at the campus and the Hyderabad city using multi hop data aggregation algorithm. A light weight middleware and a web interface to view the live pollution data in the form of numbers and charts from the test beds was developed and made available from anywhere on the internet. Other parameters like temperature and humidity were also sensed along with gas concentrations to enable data analysis through data fusion techniques. Experimentation carried out using the developed wireless air pollution monitoring system under different physical conditions show that the system collects reliable source of real time fine-grain pollution data.

Keywords:

Wireless Sensor Networks (WSN), Gas Sensor Calibration, Light Weight Middleware, Multihop Data Aggregation, Web Interface

1. INTRODUCTION

Air pollution emerged in many parts of the world as a result of explosive industrial growth. Road transport is also one of the major contributors of air pollution, which contribute to climate change that has perilous domestic and global consequences [1]. Generation and transport of pollutant materials are governed not only by the distributions of their sources but also by the dynamics of the atmosphere. Pollutant clouds are sometimes observed traveling along the wind directions [2]. To understand the involved processes in more detail, we need more thorough data on the spreads of fine-grain pollutants and their variations with time. An air pollution monitoring system that is comprehensive in terms of spatial and pollutant coverage, and is relatively inexpensive and autonomous is the priority.

Some of the existing instruments for air pollution monitoring are Fourier transform infrared (FTIR) instruments, gas chromatographs, and mass spectrometers. These instruments provide fairly accurate and selective gas readings. However high cost, large size & maintenance cost made them unfavourable for monitoring applications on large scale [3]. A gas sensor that is compact, robust, with versatile applications, and low cost could be an equally effective alternative [4]. Some of the gases monitoring technologies are electrochemical, infrared, catalytic

bead, photo ionization, and solid-state [3]. The existing monitoring system largely uses smart transducer interface module (STIM) with semiconductor gas sensors, which uses the 1451.2 standard. STIM was found to an efficient monitoring system but for the power requirements and ability to expand for large deployment. One of the large scale sensor networks for monitoring and forecasting is Environment Observation and Forecasting System (EOFS) [6], but the size of the system and initial cost is too high. Air pollution monitoring system based on geosensor network with control action and adaptive sampling rates proposed in [7] also cannot be vast deployment due to high cost.

The objective of this work is to come up with cost effective, reliable, scalable and accurate real-time air pollution monitoring system with wireless sensor networks. Commercially available electrochemical and resistive heating type sensors were used to sense the gases like O₂, CO₂, CO and NO₂. Appropriate calibration technologies were developed to calibrate these sensors, which are then interfaced to wireless sensor nodes. Zigbee based wireless sensor networks with multihop data aggregation algorithm were implemented to [13] extend the range of monitoring area. The calibration technology for the gas sensor, system architecture of real time wireless pollution monitoring system, field deployment and experimentation with varying physical conditions and various challenges faced during the design, development and deployment of the system are discussed in the following sections.

2. CALIBRATION OF GAS SENSORS

Each gas sensor is unique, i.e., though the type and the gas sensed are the same, different sensors may differ from each other in terms of the output characteristics. Therefore it becomes essential to calibrate [5] each and every sensor before interfacing to the wireless sensor node for accurate readings. Calibration of gas sensors are carried out in laboratory by exposing the sensors to different concentrations of gas.

The various stages involved in the calibration process are shown in Fig.1. A specially design closed chamber (Fig.2) setup is arranged with temperature at 25° C and at 45 to 50% RH humidity. Chamber has a provision for sending gas and taking the electrical output. Gas is sent from highly precise equipment which can maintain constant flow rates with MASS Flow controllers. Precise gas chromatography (GCC) equipment is used to measure the PPM (parts per million) of gas which is flowing through the air tight chamber. The measured raw output voltage from the sensor is found to be highly unstable and of very low magnitude. Signal conditioning circuits were designed

to stabilise and amplify the measured signal from the sensors during the calibration process. The sensors along with the conditioning circuit are placed in the chamber and readings are noted down for regular PPMs of the gas. Each sensor produces a voltage value corresponding to the input concentration of gas. These observed values are plotted and a characteristic equation is formulated to map voltage signals into corresponding concentrations in PPM. The calibration process for O₂ and CO₂ is discussed in detail in the following sections.

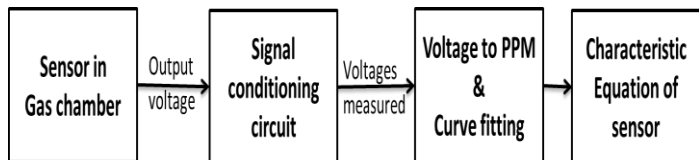

Fig.1. Various steps in the gas sensor calibration process

The test gas is a composition of 10,000ppm Carbon dioxide gas with balanced N₂ and synthesized air with 10% Hydrogen. The sensors are calibration with CO₂ concentration between 350ppm (atmospheric concentration) and 2000ppm. This type of resistive sensors is sensitive to temperature changes and room temperature of the calibration environment was maintained at around 25 degree. The flow rate was maintained at 200 ml/min in closed chamber during experiment. The gas concentration was crosschecked with gas analyser. The gas analyser reported a good match for values between 350ppm to 1200ppm and above that a 2-5% deviation of gas concentration was observed. Five sensors of the same types were calibrated. Before testing each concentration, the sensor has been exposed to atmospheric CO₂ concentration 350ppm for 10 minutes. After each tested the gas concentration will return to 350ppm before the next test starts.

The measured sensor signal strength was low, typically of the order of 220mV for the atmospheric concentration of 350ppm for CO₂ sensor and was highly unstable. To stabilize and amplify the measured signal, sensor signal conditioning circuits with amplifier and filter were used during the calibration process Fig.4.

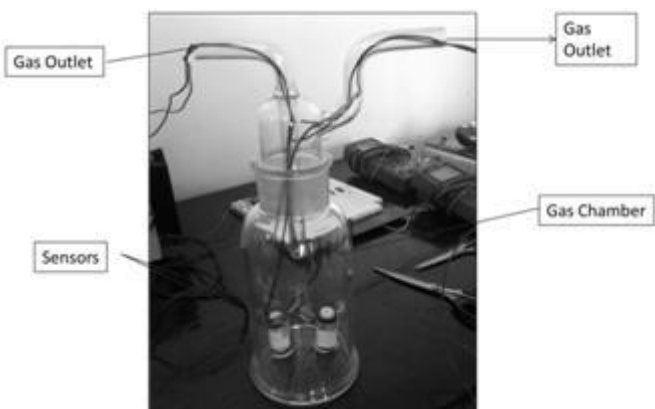

Fig.2. Gas chamber used for calibration process

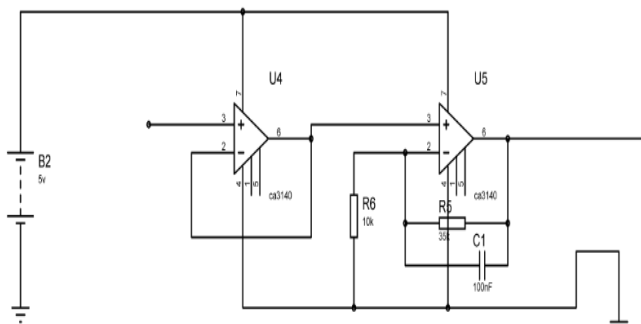

Fig.4. Signal conditioning circuit for CO₂ sensor – TGS 4161

2.1 CALIBRATION OF CARBON DIOXIDE

Figaro’s TGS4161 (Fig.3) is a solid electrolyte (a type of solid state sensor) CO₂ sensor with detection range of 350 to 5,000ppm [8]. The sensitive element of the sensor consists of a solid electrolyte formed between two electrodes, together with a printed heater substrate. CO₂ concentration is measured by monitoring the change in electromotive force (EMF) generated between the two electrodes. This type of solid electrolyte sensor features selectivity towards target gas, small in size, low cost and has long life expectancy (>10 years)[9][15].

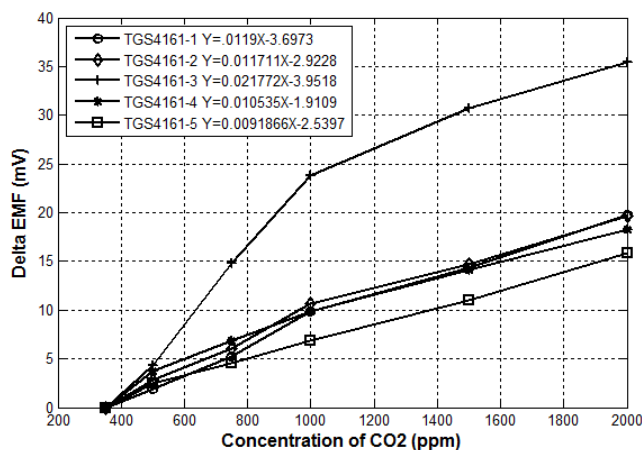

Fig.5. Calibration result for Figaro TSG4161 CO₂ sensors

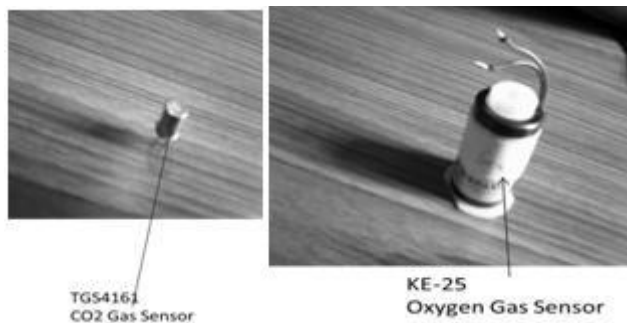

Fig.3. CO₂ and O₂ gas sensors

Calibration of the TSG4161 sensor was performed in a laboratory environment with a sealed gas chamber shown in Fig.2. The sensors were placed in the container for calibration.

Fig.5. shows the calibration results of the five different TGS4161 CO₂ sensors. It was observed that the output of TGS4161 is linear in semi-log scale up to 1000ppm and after that it slightly deviates and is approximately linear. By curve fitting, the equations for each of the sensors are arrived at which is given in Fig.5.

Calibration equation for CO₂ sensor is

For Sensor1, $y = p1*x + p2$,

where,

y is the measured voltage value

x is the concentration of CO₂

Coefficients: $p1 = 0.011992$, $p2 = -3.6973$

For the rest of the sensors, the equation is given in Fig.5.

2.2 CALIBRATION OF OXYGEN SENSORS

Figaro’s Oxygen Sensor KE-25 (Fig.3) is a unique galvanic cell type oxygen sensor, which was developed in Japan in 1985. It provides a linear output voltage signal relative to percentage of oxygen present in a particular atmosphere. The sensor features long life expectancy, excellent chemical durability, and it is not influenced by CO₂, CO, H₂S, NO_x, H₂ [10]. Moreover, it operates at normal ambient temperature and requires no warm up time making, it ideal for oxygen monitoring for portable applications.

The setup for the calibration of KE-25 was the same as the calibration of CO₂ sensors, except for the oxygen used was generated by an oxygen generator and is diluted with synthetic air. Two MFCs were used and the K-factor for Oxygen gas with H₂S calibrated was 1.24. K-factor for synthetic gas with Hydrogen calibrated was 1.48. The calibration was performed at room temperature of around 15°C and the flow rate was maintained at 300 ml/min in sealed gas chamber. The sensor is tested with different concentrations at the interval of 5% from 15% to 50%.

We have observed that the effect of temperature and humidity has negligible effect on the sensor output. KE-25 gives a very stable output voltage with amplitude between 11-14 mV in ambient air. We have employed sensor conditioning circuit with high impedance stage follow by an amplification gain of 100 in the calibration process Fig.6.

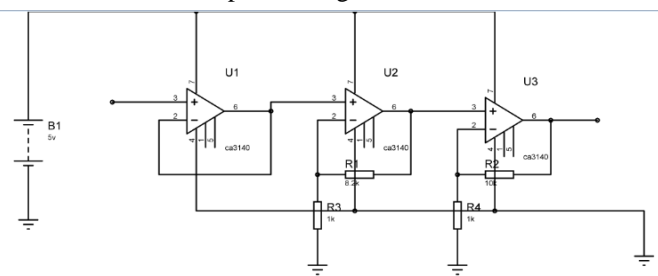

Fig.6. Signal conditioning circuit for O₂ sensor – KE-25

Fig.7 shows the calibration result of the three different KE-25 O₂ sensors. It is observed that the output of the oxygen sensor (KE-25) is linear for all range of oxygen concentration. The relation of the output voltage and gas concentration can be represented by

$$O_2 = (V_a - V_0) / (V_{100} - V_0) \quad (1)$$

where,

O_2 = measured concentration of O₂ gas

V_a = Output Voltage of the sensor at tested concentration.

V_0 = Output Voltage of the Sensor at 0% oxygen concentration

V_{100} = Voltage of the Sensor at 100% oxygen concentration

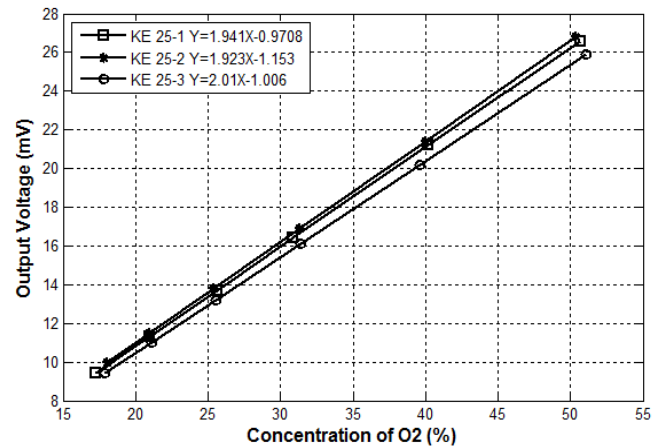

Fig.7. Calibration Result for Oxygen sensor KE-25

The calibrated equation for each of the sensor obtained after the experiment is given in Fig.7. Having calibrated the sensors, the system architecture to which these sensors are interfaced is discussed in the following section.

3. SYSTEM ARCHITECTURE OF REAL TIME WIRELESS AIR POLLUTION MONITORING SYSTEM

The real time wireless air pollution monitoring system was designed and developed to obtain the fine-grain pollution data of the gases like CO₂, O₂, NO₂, CO along with other parameters like temperature, humidity, and pressure. The architecture of the monitoring system is shown in Fig.9. The design and development of the pollution monitoring system constitutes the following stages.

1. Calibration of gas Sensors (Discussed in section II)
2. Configuring Wireless sensor nodes for air pollution monitoring
3. Development of middleware
4. Field deployment.

3.1. CONFIGURING WIRELESS SENSOR NODES FOR REAL TIME AIR POLLUTION MONITORING

The pre-calibrated commercially available gas sensors are interfaced to wireless sensor nodes/modules through the gas sensor board, which are programmed for air pollution monitoring application. Libelium Wasp nodes are used as the basic wireless communication module, which comprises of the processing unit and the communication unit Fig.8. ADC (analog to digital converter) ports of the wireless nodes are programmed to periodically sample the various gas sensors interfaced to the sensor board on a rotational basis. The collected samples are packetized and sent to base station [12] [16] at regular intervals from each of the sensor node, which forms the mesh network (Fig.9). To increase the monitoring range, multi hop data aggregation algorithm [13] was implemented. To configure RF Xbee module, gain of signal conditioning and other modules on the Wasp system refer [11]. The real time pollution monitoring test bed was developed and deployed with five node network.

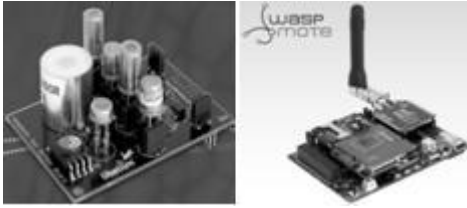

Fig.8. Libelium Wasp mote and the sensor board with different gas sensors

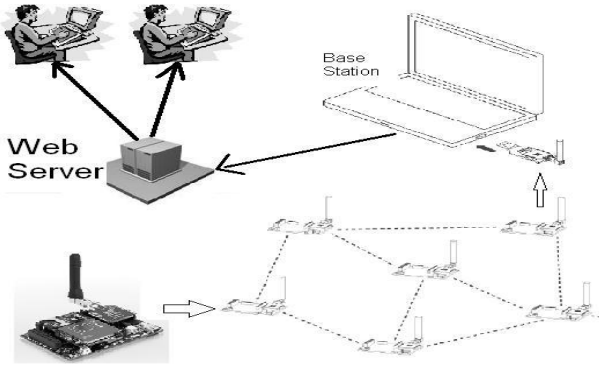

Fig.9. Multihop mesh network system architecture for the real time wireless pollution monitoring system.

3.2 LIGHT WEIGHT MIDDLEWARE AND WEB INTERFACE

Base station or the sink node receives data at regular intervals of time from the deployed network. Light weight middleware is developed for effective storage and retrieval of data. An application to read data from serial port and convert to appropriate format is developed using visual studio. Parsed data is logged in to the database in the form of tables along with the time stamp of each packet. A web based graphical user interface (GUI) is developed to view the live data in the form numbers and charts, which is made accessible from anywhere on internet.

Data is sent to the base station through multihop network. Data repository with effective, efficient and secured data transactions is required. This repository should have the facility of web based service requests as well as sms based mobile services for effective data access. Data from repository should also be targeted for sensor web enablement may be a “**sensor wiki**” for sensor information with geospatial information. Standardization in terms of gas sensor systems is to be developed like TML [17] protocol for exchanging live streaming or archived data to (i.e. control data) and/or sensor data from any sensor system. Data repository with interoperability (technologies like WIFI, Bluetooth etc..) is also incorporated.

3.3.PILOT DEPLOYMENT OF THE REAL TIME AIR POLLUTION MONITORING SYSTEM AND OBSERVATIONS:

Pilot deployment of the wireless air pollution monitoring system was carried out at two different places, namely IIT Hyderabad campus and at high trafficking area of Hyderabad city – Kukatpally. The objective of the deployment is to collect the fine grain pollutant data in these areas. The five node

pollution monitoring test bed deployed at IITH campus which is far away (30 km) from the urban polluted area is shown in Fig.10. Nodes were placed at different locations of the campus to monitor the gases like CO₂, O₂, CO and NO₂. Along with the gases concentration parameters like temperature, humidity, and pressure were also monitored at these locations. Real time plots of these gases along with other parameters are plotted with the middleware and the GUI. At IITH campus most of the times, the observed data from all of the motes seems to reflect normal atmospheric concentration of the gases, which is for CO₂ – 350 ppm, O₂ – 21%, NO₂ – 0.7 ppm and CO-0.1 ppm. Experiments were performed by exposing some of the sensor nodes in the network to different physical conditions. Accordingly, one of the sensor nodes (mote1) was placed near the exhaust of the motor bike. The collected data from this node shows CO₂ concentration of 900 to 1000 PPM with variation in acceleration of bike. It’s also been observed that when the motor bike is switched off CO₂ concentration come back to its normal atmospheric level of 350 to 380 PPM after some time. Other important observations are O₂ concentration is decreasing along with temperature and humidity variations Fig.11. One more experimentation was carried out were number of people near one of the motes was increased and the CO₂ concentration was found to increase as shown in Fig.12.

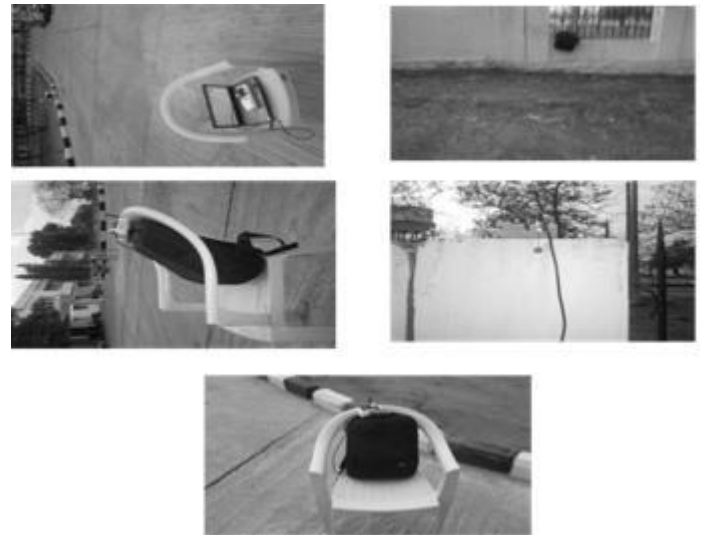

Fig.10. Wireless air pollution monitoring system deployed at IITH campus

Data collected from the next deployment at Kukatpally which is highly dense traffic area is shown in Fig.13. The CO₂ levels are almost at 1600-1800 PPM, we observe minor changes in NO₂ concentrations but are under safety limits. Oxygen levels are not very much varying except 0.1 to 0.2 % variations. Temperature was observed to be low and humidity was slightly higher. Level of pollutant was significantly high at Kukatpally as on the day of measurement there was rain.

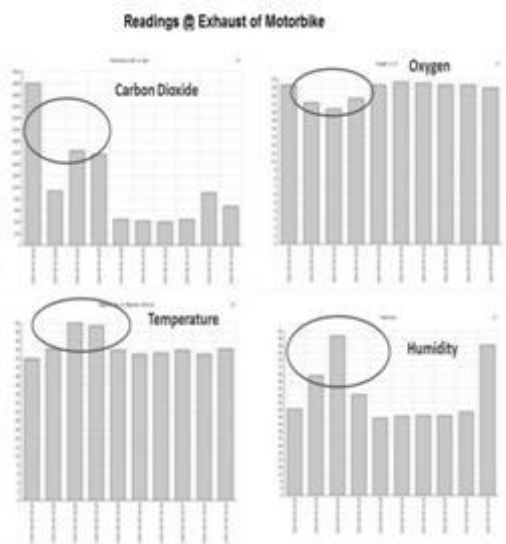

Fig.11. Gas concentration for mote-1 near the exhaust of motorbike

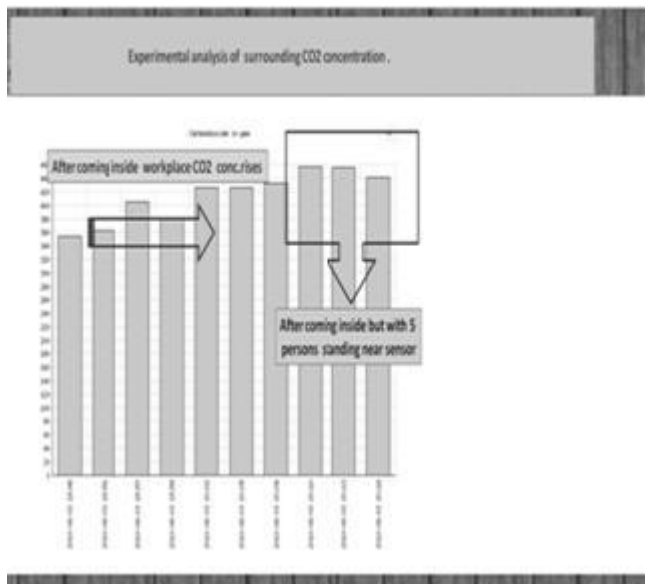

Fig.12. CO2 gas concentration for a mote surrounded by more number of people

3.4. ISSUES FACED DURING THE DESIGN AND DEVELOPMENT OF THE SYSTEM

Air pollution sensors like CO₂, CO and NO₂ are resistive heating based sensors. They consume a lot of energy from the battery of wireless nodes which is detrimental to network life time. Chemical /MOSFET sensors need very less power but the cost is too high. The effect of temperature and humidity on resistive type gas sensors is to be considered for accurate readings. Calibration at periodic intervals is necessary but it is difficult to do for large no of sensors in field. Life of the sensors is very short (typically 6 to 9 months)[14]. Also the costs of Libelium motes were too high. In the next phase of the project, we plan to design and develop cost effective architectures for pollution monitoring systems. Energy of the wireless sensor

nodes should be utilized optimally. The sensed data from every node is sent at regular intervals of time. Data compression and data modeling algorithms helps in saving the energy of node by reducing the redundant data. Data should have geospatial information for better visualization or analysis of data. Sensor nodes should have the capability of estimation, quantification of the data. Sleep modes also to be included considering the statistics of the data received.

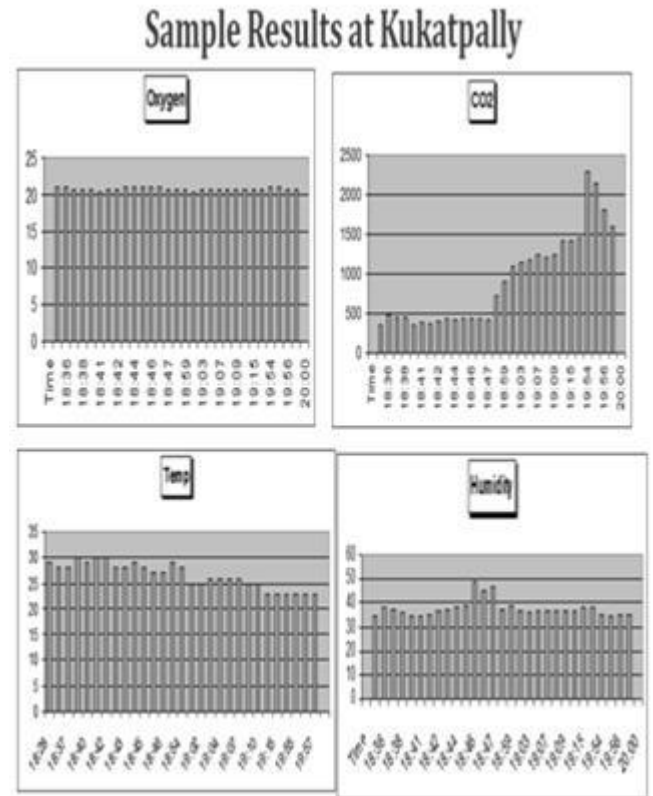

Fig.13. Data collected at Kukatpally using wireless pollution monitoring system

4. CONCLUSIONS

The importance of real-time wireless air pollution monitoring system is investigated considering the vital technical and economic issues for vast area deployment. Commercially available gas sensors were calibrated using the appropriate calibration technologies. These pre-calibrated sensors are then interfaced with the wireless sensor motes forming multi hop mesh network. A light weight middleware and web based interface were developed for online monitoring of the data in the form of charts from anywhere on internet. Pilot deployment of the system was carried out at the campus and at the Hyderabad city. Experimentation carried out using the developed wireless air pollution monitoring system under different physical conditions show that the system collects reliable source of real time fine-grain pollution data.

REFERENCES

[1] Department of Transport, “Transport ten year plan” The Stationary Office, London, 2000.

- [2] J. C. St. John and W. L. Chameides, "Environ. Science Techno 31", pp. 2797-2804, 1997.
- [3] IST, Chapter 1—Introduction "International Sensor Technology", pp.1-4.
- [4] D. D. Lee and D. S. Lee, "Environmental gas sensors," *IEEE Sensors J.*, Vol. 1, No. 3, pp. 214–215, 2001.
- [5] Nihal Kularatna, and B. H. Sudantha, "An Environmental Air Pollution Monitoring System Based on the IEEE 1451 Standard for Low Cost Requirements" *IEEE Sensors Journal*, Vol. 8, No. 4, 2008.
- [6] Xu, N, "A Survey of Sensor Network Applications," *IEEE Communications Magazine*, Vol. 40, No.8, pp. 102-114, 2002.
- [7] Young Jin Jung, Yang Koo Lee, Dong Gyu Lee, Keun Ho Ryu, Silvia Nittel "Air pollution monitoring system based on geosensor network", *IEEE International Geoscience and Remote Sensing Symposium*, pp.III-1370–III-1373, 2008.
- [8] Gas board technical guide – Libelium system, <http://www.libelium.com/support>
- [9] Muna Acosta, Designing with Electro-Chemical Sensors, National Instrument Application Note AN-1798. [10] "Electrochemical CO sensors", Targeted Wind Sensing.
- [10] http://tws.unh.edu/index.php?option=com_content&task=view&id=63&Itemid=7
- [11] Wasp mote technical guide-libelium system, <http://www.libelium.com/support>
- [12] Sung-Hwa Hong, Byongguk Kim, and Doo-Seop Eom, "A Base-station Centric Data Gathering Routing Protocol in Sensor Networks Useful in Home Automation Applications", *IEEE Transactions on Consumer Electronics*, Vol. 53, No. 3, pp. 945 – 951, 2007.
- [13] Mohd Adib B. Sarijari, Rozeha A. Rashid, Mohd Rozaini Abd Rahim, Nur Hija Mahalin, "Wireless Home Security and Automation System Utilizing ZigBee based Multi-hop Communication" *IEEE 2008 6th National Conference on Telecommunication Technologies and IEEE 2008 2nd Malaysia Conference on Photonics*, Putrajaya, Malaysia.
- [14] S.Bicelli , A.Flammini , A. Depari , D. Marioli , A. Ponzoni , G.Sberveglieri , A.Taroni, "Low-Power Carbon Monoxide MOX Sensors for Wireless Distributed Sensor Networks" *Instrumentation and Measurement Technology Conference - IMTC 2007* Warsaw, Poland, 2007.
- [15] Wen Wang, Taehyun Kim, Keekeun Lee, Haekwan Oh, and Sangsik Yang, "Development of a New Wireless Chemical Sensor for CO2 detection" *IEEE SENSORS Conference*, 2007.
- [16] Gongbo Zhou, Zhencai Zhu, Guangzhu Chen, Ningning Hu, "Energy-Efficient Chain-type Wireless Sensor Network for Gas Monitoring" *Second International Conference on Information and Computing Science*, 2009.
- [17] <http://www.opengeospatial.org/standards/html>.